

Product datasheet

Specifications

TSXCTY2C Product picture Schneider

Electric

⚠ Discontinued - Service only

2 channels measurement
and counter module - 15 mA
at 24 V DC, 850 mA at 5 V
DC

TSXCTY2C

⚠ Discontinued on: 23 Jan 2021

⚠ To be end-of-service on: 31 Dec 2026

Main

Range Of Product	Modicon Premium Automation platform
Product Or Component Type	Measurement and counter module
I/O Modularity	2 channels
Electrical Circuit Type	Auxiliary output conforming to EN/IEC 61131-2

Complementary

Counting Frequency	1000000 Hz
Incremental Encoder Frequency X1	500 kHz
Incremental Encoder Frequency X4	250 kHz
Power Dissipation In W	7...10 W
Cycle Time	1 ms
Discrete Input Logic	Current sink for auxiliary input (preset, enable and read) conforming to IEC 1131 Type 2 Resistive for 2/3-wire proximity sensors PNP/NPN conforming to IEC 1131 Type 2 Resistive for encoder input
Input Logic	Positive
Input Compatibility	Absolute encoder parallel output ABE7CPA11 Incremental encoder 10...30 V totem pole Incremental encoder 5 V DC RS422 Absolute encoder SSI serial output
Input Voltage	24 V 16 mA 2/3-wire proximity sensors PNP/NPN 24 V 8 mA auxiliary input (preset, enable and read) 5 V 18 mA encoder input
Input Voltage Limits	<= 5.5 V encoder input 19...30 V 2/3-wire proximity sensors PNP/NPN 19...30 V auxiliary input (preset, enable and read)
Voltage State 1 Guaranteed	>= 11 V for 2/3-wire proximity sensors PNP/NPN >= 11 V for auxiliary input (preset, enable and read) >= 2.4 V for encoder input
Current State 1 Guaranteed	>= 6 mA (2/3-wire proximity sensors PNP/NPN) >= 6 mA (auxiliary input (preset, enable and read)) >= 3.6 mA (encoder input)
Voltage State 0 Guaranteed	<= 1.2 V for encoder input <= 5 V for 2/3-wire proximity sensors PNP/NPN <= 5 V for auxiliary input (preset, enable and read)

Current State 0 Guaranteed	<= 1 mA (encoder input) <= 2 mA (2/3-wire proximity sensors PNP/NPN) <= 2 mA (auxiliary input (preset, enable and read))
Response Time	< 10 ms sensor voltage at return of 24 V auxiliary input (preset, enable and read) < 2.5 ms sensor voltage at loss of 24 V auxiliary input (preset, enable and read)
Input Impedance	Encoder input: > 270 Ohm at U = 2.4 V 2/3-wire proximity sensors PNP/NPN: 1500 Ohm at Un Auxiliary input (preset, enable and read): 3400 Ohm at Un Encoder input: 400 Ohm at Un
Output Voltage	24 V DC
Nominal Output Current	0.5 A
Output Voltage Limits	19...30 V
Maximum Voltage Drop	<0.5 V at state 1
Output Compatibility	Positive logic DC inputs (resistance <= 15 kOhm) for auxiliary output
Maximum Leakage Current	0.1 mA
Switching Time	< 0.250 ms
Switching Frequency	< 0.6/LI² Hz on inductive load load
Output Overload Protection	Thermal tripping via program or automatically Current limiter
Output Short-Circuit Protection	Thermal tripping via program or automatically Current limiter
Output Overvoltage Protection	Zener diode
Reverse Polarity Protection	Reverse diode on supply
Checks	Sensor power supply
Current Consumption	15 mA at 24 V DC 850 mA at 5 V DC
Module Format	Standard
Local Signalling	1 LED (green) for module operating (RUN) 1 LED (red) for external fault (I/O) 1 LED (red) for internal fault, module failure (ERR) 2 LEDs (green) for axis diagnostics available (CH.)
Electrical Connection	1 connector HE-10, 20 pins 2 connectors SUB-D 15
Net Weight	0.34 kg

Environment

Protective Treatment	TC
Ambient Air Temperature For Operation	0...60 °C
Ambient Air Temperature For Storage	-25...70 °C
Relative Humidity	5...95 % without condensation
Operating Altitude	<= 2000 m

Packing Units

Unit Type Of Package 1	PCE
Number Of Units In Package 1	1
Package 1 Height	5.5 cm
Package 1 Width	18.0 cm

Package 1 Length	26.0 cm
Package 1 Weight	587.0 g
Unit Type Of Package 2	S03
Number Of Units In Package 2	8
Package 2 Height	30.0 cm
Package 2 Width	30.0 cm
Package 2 Length	40.0 cm
Package 2 Weight	4.9 kg

Contractual warranty

Warranty	12 months
----------	-----------

Product datasheet TSXCTY2C

Dimensions Drawings

Standard and Extendable Racks for Modules Mounting

Dimensions of Modules and Racks

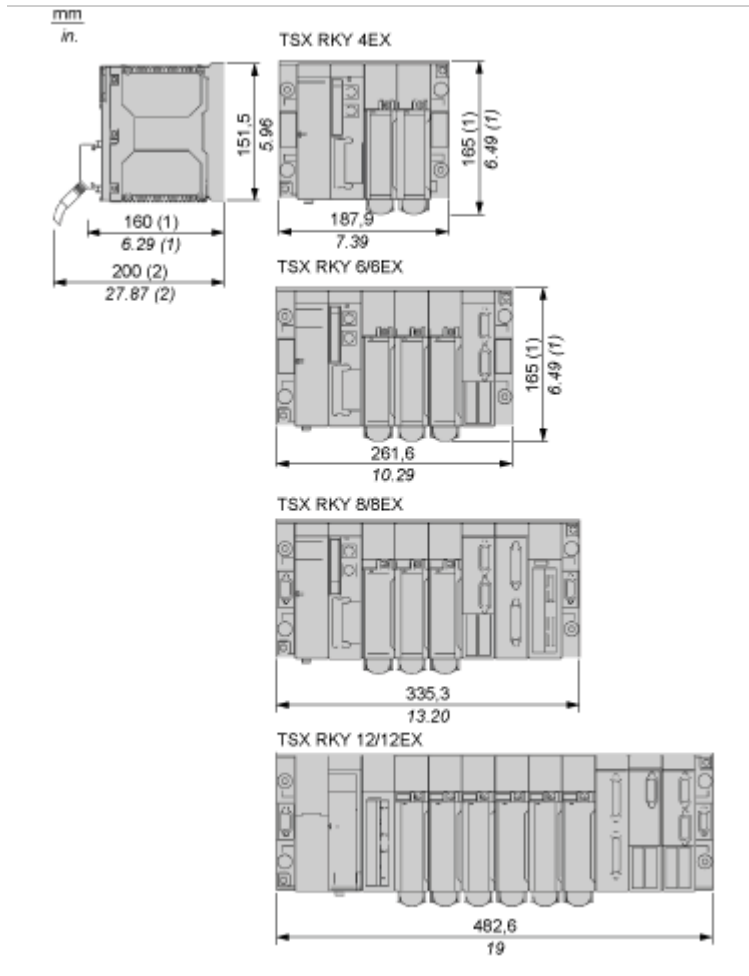

(1) With screw terminal block modules.

(2) Maximum depth for all types of modules and their associated connectors.

15-pin SUB-D Connectors of the Measurement and Counting Module

Pinout Configuration

Standard 15-pin SUB-D connector for connecting the counting sensor to channels 0, 1, 2 or 3

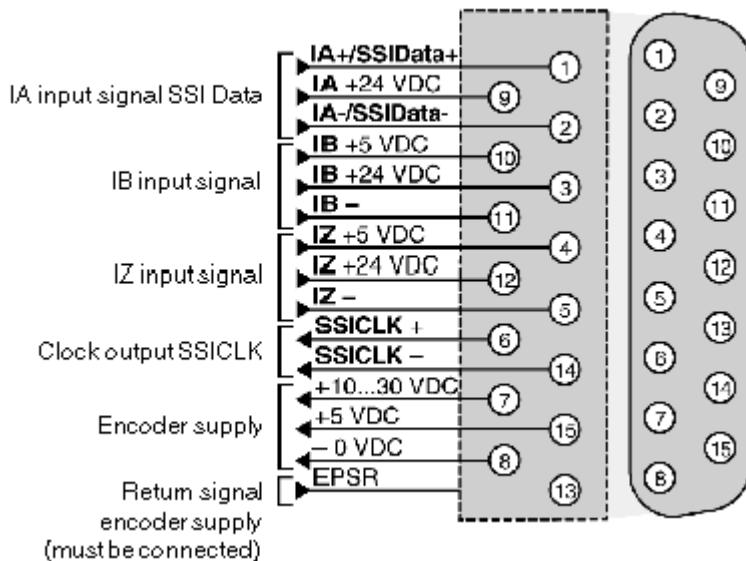

5 Vdc signal	Pins
+ IA input	1
- IA input	2
+ IB input	10
- IB input	11
+ IZ input	4
- IZ input	5
Encoder power supply:	
+5 Vdc	15
-0 Vdc	8
Encoder power supply feedback	13

10...30 Vdc signals	Pins
+ IA input	9
- IA input	2
+ IB input	3
- IB input	11

10...30 Vdc signals	Pins
+ IZ input	12
- IZ input	5
Encoder power supply:	
+10...30 Vdc	7
-0 Vdc	8
Encoder power supply feedback	13

Serial signals (absolute encoder with serial or parallel outputs, using a TELEFAST ABE7CPA11 adapter)	Pins
+ SSI Data	1
- SSI Data	2
+ SSI CLK input	6
- SSI CLK input	14
Encoder power supply:	
+5 Vdc	15
-0 Vdc	8
Encoder power supply feedback	13

20-pin HE10 Connector of the Measurement and Counting Module

Wiring Diagram

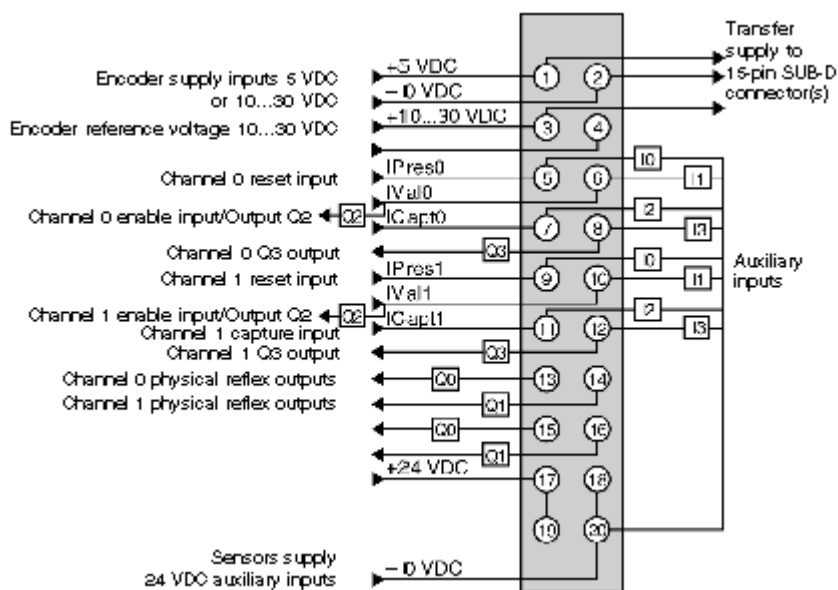

24 Vdc signals	Pins
Channel 0 auxiliary input:	
Preset IPres0	5
Confirmation IVal0/Output Q2	6
Capture ICapt0	7
Output Q3	8
Channel 1 auxiliary input:	
Preset IPres1	9
Confirmation IVal1/Output Q2	10
Capture ICapt1	11
Output Q3	12
Channel 0 reflex output:	
Output Q0	13
Output Q1	14
Channel 1 reflex output:	
Output Q0	15

24 Vdc signals	Pins
Output Q1	16

Power Supplies	Pins
Encoder power supply:	
+5 Vdc	1
- 0 Vdc	2
+10...30 Vdc	3
Encoder reference voltage +10...30 Vdc	4
Sensor power supply:	
+24 Vdc	17 or 19
-0 Vdc	18 or 20